

UPS

**TRUE
FRONT
ACCESS
HIGH RATE MAX**

**UPS 12-410 MRXF
UPS 12-615 MRXF
UPS 12-700 MRXF**



**Valve Regulated Lead Acid (VRLA) Battery Series
Design For UPS Standby Power Applications**

APPLICATIONS

- Data Centers
- Network Operations Centers
- Industrial Process Control Facilities
- Internet Housing Sites
- Semiconductor Manufacturing
- Banks & Financial Markets
- Power Generation Plants
- Hospitals & Testing Laboratories
- Emergency 911 Response Centers

FEATURES & BENEFITS

- 10 year design life @ 25°C
- True Front Access threaded copper alloy inserts, for reduced maintenance and increased safety
- Terminal versatility - ease of diagnostic readings with C&D Ohmic Ring®
- Innovative front terminal design maximizing energy density with direct connect extrusion fusion weld technology
- Reduced headspace driving higher energy density, in cabinet or rack applications
- Removable handles for ease of installation
- Thermally welded case-to-cover bond to ensure a leak-proof seal
- Flame-retardant polypropylene case and cover compliant with UL94 V-0 with an Oxygen Limiting Index of greater than 28
- Absorbent Glass Mat (AGM) technology for efficient gas recombination of over 99%
- Flame-arresting, one-way pressure-relief vent for safety and long life
- Complies with UL 1778,924,1989 and 94 V-0. BS6290-4, IEC-896-2
- UL-recognized component
- Multicell design for ease of installation and maintenance
- Not restricted for air transport - Complies with IATA/ICAO Special Provision A67
- Not restricted for surface transport – Classified as non-hazardous material as related to DOT-CFR Title 49 parts 171-189
- 3 Year Full Warranty (refer to warranty card, 41-9027)
- Not restricted for water transport – Classified as non-hazardous material IMDG Amendment 27

TECHNICAL DATA

Model	Voltage	AH 20 hr*	Constant Power Discharge Ratings - Watts Per Cell @ 77°F (25°C)								
			Operating Time (in minutes) to 1.67 Volts per Cell								
			5	10	15	20	30	40	50	60	90
UPS 12-410 MRXF	12	109	701.1	514.6	410.0	339.5	256.0	203.1	169.8	146.6	105.1
UPS 12-615 MRXF	12	172	1027.1	771.8	615.0	513.8	392.5	318.8	271.3	237.8	171.5
UPS 12-700 MRXF	12	201	1117.8	866.0	700.0	583.0	453.0	368.1	313.3	274.7	199.3

*True 20 hr rate to 1.75 VPC in Ampere-hours

INTRODUCING A UPS FRONT ACCESS BATTERY WITH TRUE FRONT ACCESS TERMINALS

- **Direct welded front facing terminals**
 - Uses proven Extrusion Fusion welding process for high reliability
 - Provides most efficient current path for excellent high rate performance
 - No bolted on "L" brackets which try to make a top terminals battery into a front terminal battery
 - One less bolted connection that requires maintenance, builds up resistance, and can lead to poor string performance
- **Designed as a UPS battery from the ground up to efficiently handle high rate discharges**
 - Not a converted telecom front access battery
- **Raised Terminals for ease of maintenance and access to C&D Ohmic Ring®**

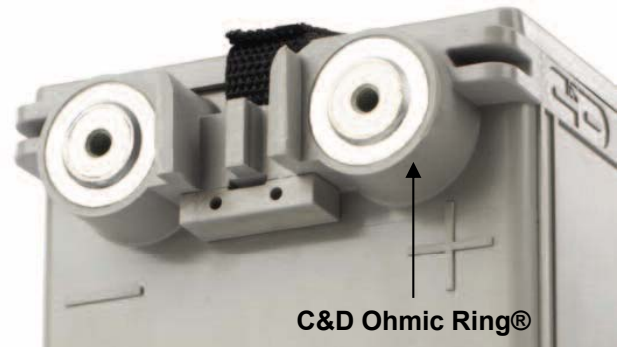

C&D Ohmic Ring®

- **Large surface area for direct access to terminals for accurate ohmic measurements**
 - No more taking readings from bus bars or hardware which can lead to substantial errors
- **Provides consistent and accurate measuring location**
 - No guessing to what point was the base line reading taken from
- **Ideally sized for use with standard monitor probes on fully installed systems**
- **The Ohmic Ring design is the only terminal configuration in which micro-ohm connection resistances can be taken as required by standard maintenance programs.**

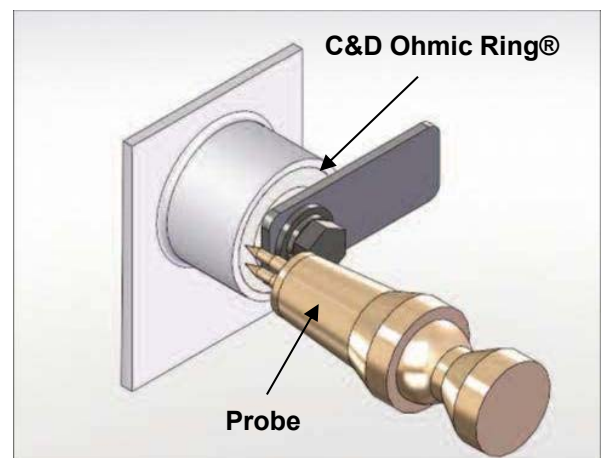

The True Front Access UPS Battery - The Better UPS Battery Solution

- Eliminate hard to service top terminal batteries with a full front access solution
- Higher watts per cell allows a reduction of a parallel string for most common UPS configurations, providing a reduced footprint solution
- Maintenance is significantly easier and safer with all required service points front accessible - reducing both time and cost of periodic servicing
- As a 12V battery design, the UPS12-615 MRXF and UPS12-700 MRXF easily integrate with existing battery monitoring equipment.

SPECIFICATIONS

Operating Temperature Range with temperature compensation	Discharge: -40°F (-40°C) to +160°F (71°C) Charge: -10°F (-23°C) to +140°F (60°C)
Nominal Operating Temperature Range	+74°F (23°C) to +80°F (27°C)
Recommended Maximum Charging Current Limit	C/5 amperes @ 20hr rate
Float Charging Voltage	13.5 to 13.8 VDC average per 12V unit @ 77°F (25°C)
Maximum AC Ripple (Charger)	0.5% RMS or 1.5% P-P of float charge voltage recommended for best results. Max voltage allowed = 1.4% RMS (4% P-P) Max current allowed = C/20
Self Discharge	Battery can be stored up to 6 months at 77°F (25°C) before a freshening charge is required. Batteries stored at temperatures greater than 77°F (25°C) will require recharge sooner than batteries stored at lower temperatures. See C&D brochure 41-7272, Self-Discharge and Inventory Control for details.
Terminal: Inserted - Inter-unit connector provided	Threaded copper alloy insert terminal to accept: M8 bolt (UPS 12-700 MRXF, UPS 12-615 MRXF) M6 bolt (UPS 12-410 MRXF)
Terminal Hardware Initial Torque	160 in.-lbs. (18 N-m) for: UPS 12-700 MRXF, UPS 12-615 MRXF 107 in.-lbs (12 N-m) for UPS 12-410 MRXF

SPECIFICATIONS

Battery Model	Voltage Per Unit	Ampere Hours Capacity 20 Hour Rate @ 77°F (25°C) to 1.75EPV per cell	Ampere Hours Capacity 10 Hour Rate @ 68°F (20°C) to 1.80EPV per cell	IEC Short Circuit Current (A)	IEC Resistance (mOhms)	Weight (kg)
UPS 12-410 MRXF	12V	109	100	2860	4.4	37.1
UPS 12-615 MRXF	12V	172	160	3700	3.4	55.2
UPS 12-700 MRXF	12V	201	185	4400	2.8	64.9

Battery Model	Hioki Impedance (mOhms)	Midtronics Cond. (Mhos)	Short Circuit Current (AMPS @0.1 sec)	Maximum Terminal Discharge Current Rating (AMPS)
UPS 12-410 MRXF	2.37	2000	4900	800
UPS 12-615 MRXF	1.91	2500	6500	800
UPS 12-700 MRXF	1.84	2700	7900	800

* Per IEEE 1188-2005, Internal ohmic values are useful as a trending tool. To use these readings effectively, accurate baseline readings should be taken after about six months of battery operation. Internal ohmic readings taken without the benefit of baseline data may be difficult to interpret and of limited value. Values are provided are for reference only.

Dimensions

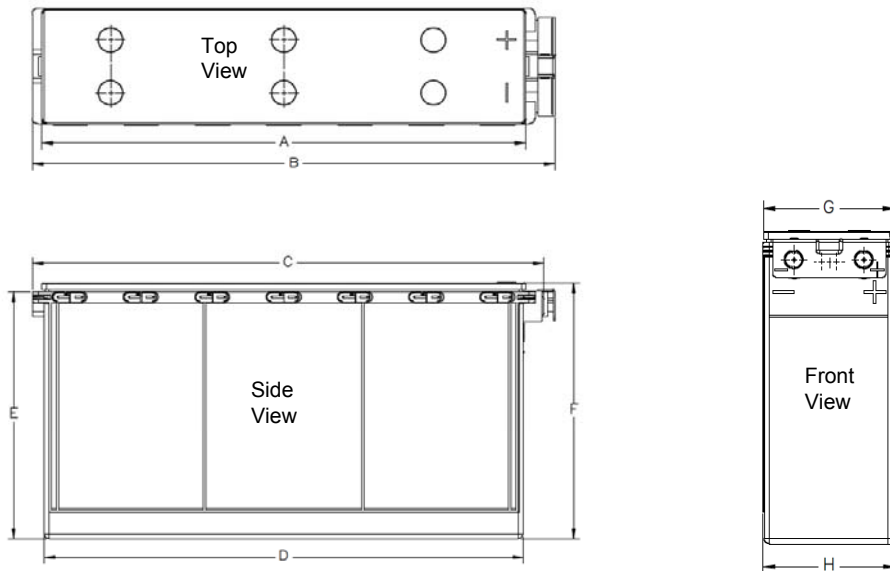

Model	A		B		C		D		E		F		G		H	
	in	mm	in	mm	in	mm	in	mm	in	mm	in	mm	in	mm	in	mm
UPS 12-410 MRXF	18.6	473.1	20.1	510.5	19.6	498.3	18.5	469.5	8.5	215.2	9.1	231.4	4.3	109.0	4.3	108.0
UPS 12-615 MRXF	20.3	516.9	22.0	558.5	21.5	546.5	20.2	512.2	10.6	268.9	11.0	278.7	4.9	125.0	4.9	123.4
UPS 12-700 MRXF	20.3	516.9	22.0	558.5	21.5	546.5	20.2	512.2	12.2	310.3	12.7	321.6	4.9	125.0	4.9	123.4

*All dimensions in inches and (millimeters). All dimensions are for reference only. Contact a C&D Representative for complete dimensions information.

Detail of Terminal

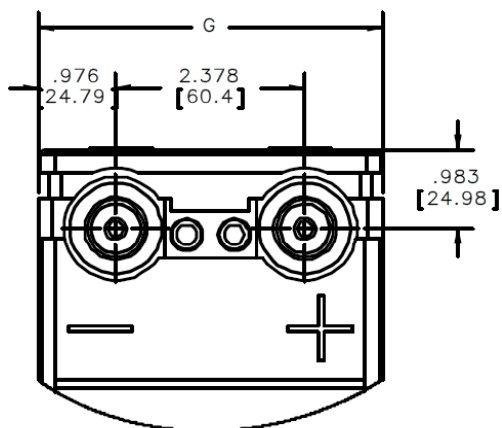

UPS 12-410 MRXF

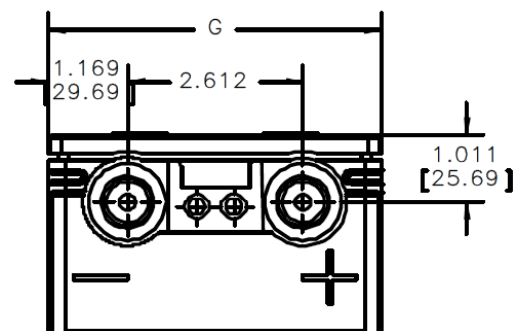

UPS 12-615 MRXF
UPS 12-700 MRXF

UPS 12- 410 MRXF

Constant Power Discharge Ratings - Watts Per Cell @ 77°F (25°C)										
Operating Time to End Point Voltage (in minutes)										
End Point Volts/Cell	5	10	15	20	30	40	45	50	60	90
1.75	660.1	484.4	386.0	321.2	244.0	195.3	178.3	164.3	142.7	102.4
1.70	690.8	507.0	404.0	334.4	252.0	200.5	182.6	167.9	145.3	104.2
1.67	701.1	514.6	410.0	339.5	256.0	203.1	184.8	169.8	146.6	105.1
1.65	709.7	520.8	415.0	344.1	260.0	205.7	186.9	171.6	147.9	106.0

Constant Current Discharge Ratings - Amperes @ 77°F (25°C)										
Operating Time to End Point Voltage (in hours)										
End Point Volts/Cell	1	2	3	5	8	10	12	20	24	72
1.85	67	38.4	27.7	18.5	12.0	9.7	8.2	5.07	4.28	1.50
1.80	71	40.5	29.2	19.4	12.6	10.2	8.6	5.34	4.50	1.58
1.75	73	41.5	29.8	19.8	12.8	10.4	8.8	5.46	4.61	1.61

UPS 12- 615 MRXF

Constant Power Discharge Ratings - Watts Per Cell @ 77°F (25°C)										
Operating Time to End Point Voltage (in minutes)										
End Point Volts/Cell	5	10	15	20	30	40	45	50	60	90
1.75	973.6	731.7	583.0	494.2	386.0	313.6	288.0	266.9	234.0	169.0
1.70	1010.4	759.3	605.0	508.0	391.0	317.4	291.4	269.9	236.5	170.7
1.67	1027.1	771.8	615.0	513.8	392.5	318.8	292.8	271.3	237.8	171.5
1.65	1035.4	778.1	620.0	516.8	393.5	319.5	293.4	271.8	238.2	172.0

Constant Current Discharge Ratings - Amperes @ 77°F (25°C)										
Operating Time to End Point Voltage (in hours)										
End Point Volts/Cell	1	2	3	5	8	10	12	20	24	72
1.85	109	61.8	44.0	28.7	19.0	15.5	13.1	8.10	6.81	2.38
1.80	118	65.8	46.7	30.4	20.1	16.3	13.8	8.47	7.12	2.49
1.75	120	67.0	47.5	30.9	20.3	16.5	13.9	8.61	7.26	2.54

Note: Batteries to be mounted with 0.5 in. (1.25 cm) spacing minimum and free air ventilation. Specifications subject to change without notification. Above ratings do not include interunit connector voltage drops.

UPS 12-700 MRXF

Constant Power Discharge Ratings - Watts Per Cell @ 77°F (25°C)										
Operating Time to End Point Voltage (in minutes)										
End Point Volts/Cell	5	10	15	20	30	40	45	50	60	90
1.75	1020.6	780.0	630.0	544.1	437.0	358.7	330.8	307.7	271.5	196.5
1.70	1083.8	839.6	669.0	570.2	449.0	365.5	336.0	311.6	273.5	198.6
1.67	1117.8	866.0	700.0	583.0	453.0	368.1	338.1	313.3	274.7	199.3
1.65	1134.0	878.5	703.0	590.1	457.0	370.3	339.7	314.5	275.2	199.7

Constant Current Discharge Ratings - Amperes @ 77°F (25°C)										
Operating Time to End Point Voltage (in hours)										
End Point Volts/Cell	1	2	3	5	8	10	12	20	24	72
1.85	121	71.4	51.1	33.5	22.1	18.0	15.2	9.48	8.01	2.80
1.80	130	75.1	53.9	35.2	23.2	18.8	15.9	9.88	8.34	2.92
1.75	134	76.6	54.6	35.7	23.6	19.2	16.2	10.07	8.51	2.98

Note: Batteries to be mounted with 0.5 in. (1.25 cm) spacing minimum and free air ventilation. Specifications subject to change without notification. Above ratings do not include interunit connector voltage drops.